

TECHNICRETE Concrete Kerbs the ideal edge restraint

<p>300 x 175 x 75 Mountable (fig 8B)</p>		
<p>300 x 200 x 100 Mountable (fig 8C)</p>		
<p>100 x 250 Edge/Channel (fig 10)</p>		
<p>150 x 210 Edge (fig 16S)</p>		
<p>75 x 230 Rectangular Industrial Kerb T & G</p>		
<p>75 x 150 Rectangular Garden Kerb T & G</p>		

Technicrete reserves the right to change or amend the contents of this document at anytime without any notice with this document intended for general information only. Any specific information required about product specifications, applications, technical information, sales conditions, warranties and guarantees as required for any design or installation should be obtained from Technicrete.

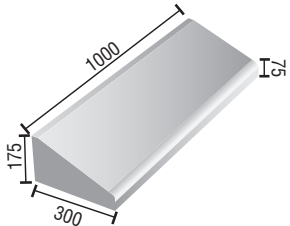
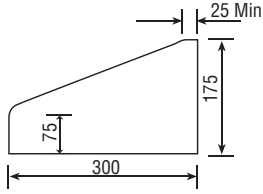
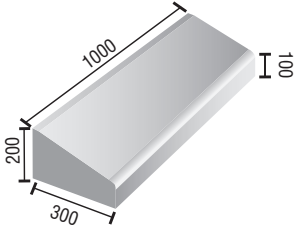
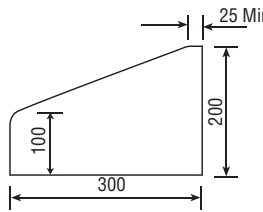
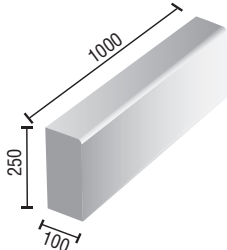
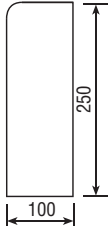
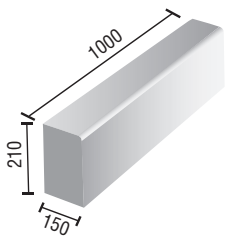
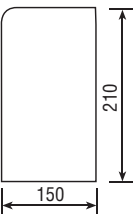
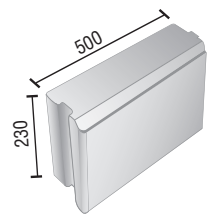
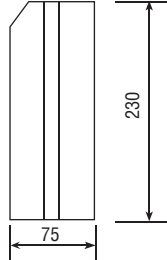
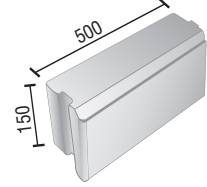
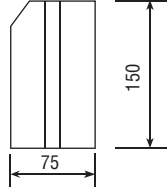

Technicrete ISG
Cnr. Main Reef Road & Houtkapper Street, Roodepoort, 1725
Tel: 011 674 6900 – Fax: 086 685 1148
Email: info@technicrete.co.za
www.technicrete.co.za
0861 266267



TECHNICRETE Kerbs

The all round edge restraint

The versatile precast kerbs are used for edge restraint in the construction of roads, kerbs, gutter systems, rumble strips and many other uses.

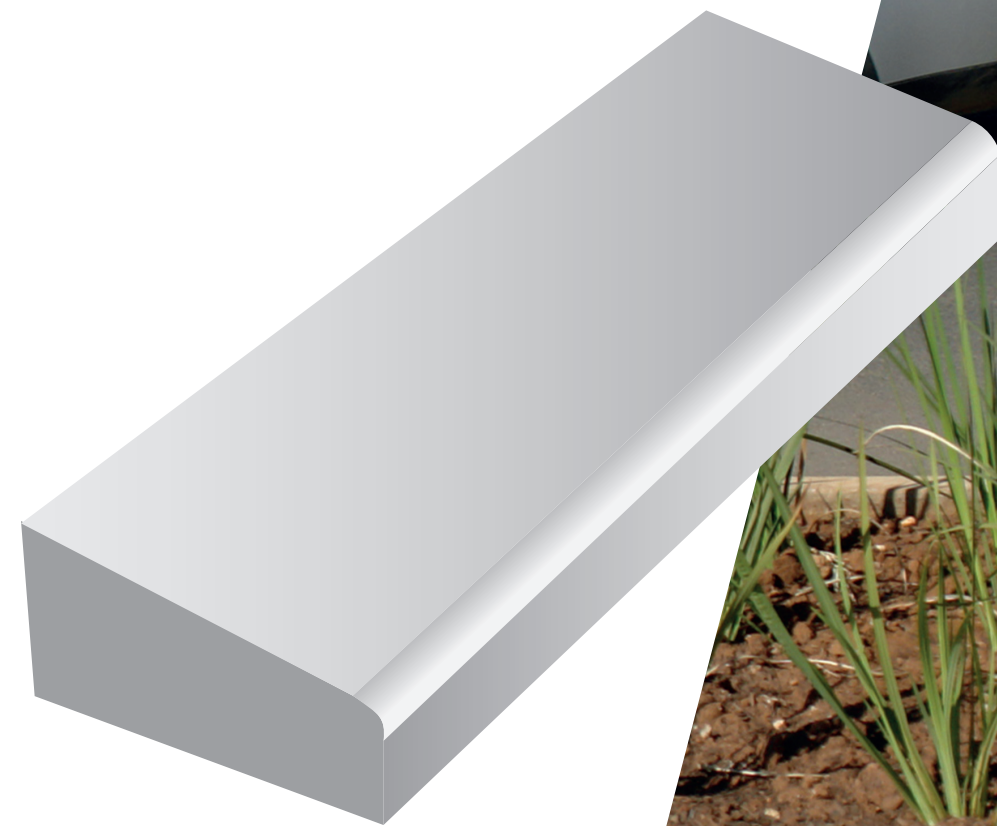

TECHNICRETE
quality support

PAVING • SPECIAL PRODUCTS • KERBS • MASONRY • SHOTCRETES
EROSION PROTECTION BLOCKS • MINING • TRAFFIC CALMING BLOCK • PREBAGGED PRODUCTS
PRECAST PRODUCTS • RETAINING WALLS • SLOPE SUPPORT SYSTEMS • HEAVY DUTY PAVEMENTS

Branches:
Gauteng: Olifantsfontein 011 206-8920
Clayville 011 316-2375
Waterfall 011 316-2375
Carletonville 087 354-8620
Mpumalanga: Witbank 013 696-1153
North West: Stilfontein 018 484-3089
Limpopo: Polokwane 015 298-8083
Free State: Welkom 057 391-4200

