

**TECHNICRETE**

# Deckwerk<sup>®</sup>

**Technicrete Deckwerk<sup>®</sup>**, heavy duty blocks for erosion protection and heavy traffic applications. 3-way lock gives both horizontal and vertical interlock.

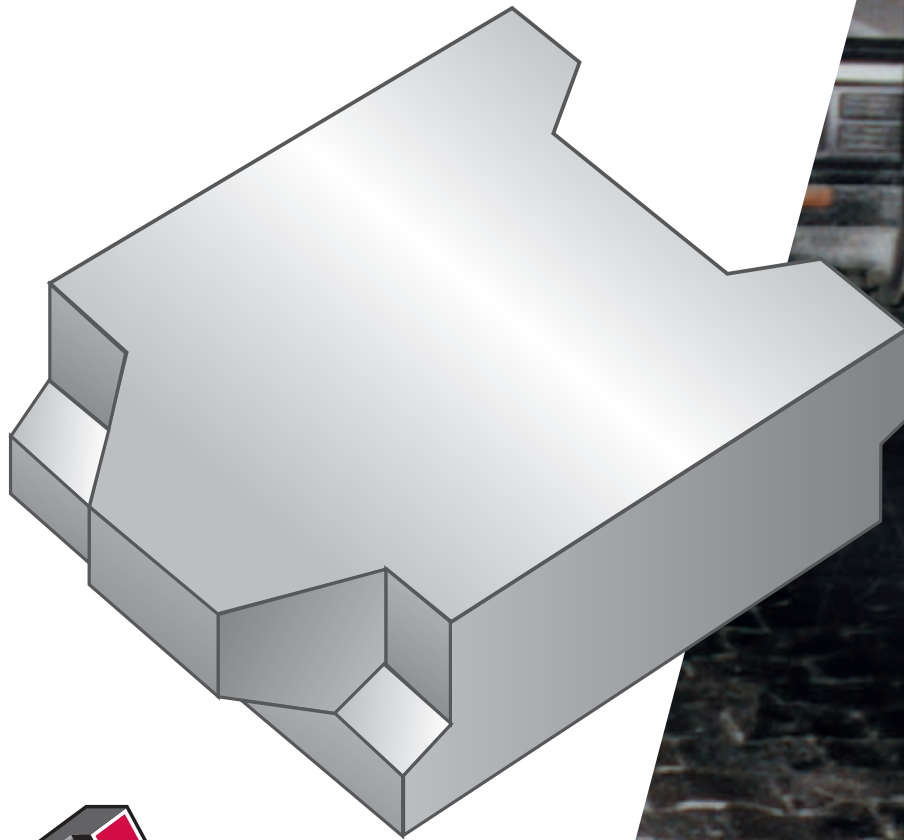

**TECHNICRETE**  
quality support

CONCRETE ROOF TILES • **HEAVY DUTY PAVEMENTS** • KERBS • MASONRY •  
PAVING • PRECAST PRODUCTS • RETAINING WALLS • STOPE SUPPORT SYSTEMS



# Deckwerk<sup>®</sup> heavy duty block with 3-way interlock

**Technicrete Deckwerk<sup>®</sup> heavy duty blocks for erosion protection and heavy traffic applications. 3-way lock gives both horizontal and vertical interlock.**

Conventional interlocking block paving has proved to be a superior surfacing in many applications. With the use of mechanical interlocking blocks, the scope of suitable applications is made even wider.

Advantages of mechanical interlocking blocks: Maintains integrity with surrounding blocks / any ground settlements will not dislodge an individual block / resists uplift forces when used in channels or in sludge drying areas / security against uplift by non authorized persons is greatly improved / load transfer is direct from block to block and not via the jointing sand alone, jointing sand is less susceptible to blow out or wash out / added resistance to uplift on steep slopes.

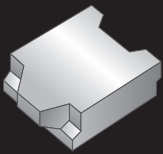
	<i>Applications</i>	No. of blocks per m <sup>2</sup> at nominal size	Colours available	Special features	Size Length x Width Thickness
	<i>Flexible concrete linings Storm water channels &amp; canals Spillways &amp; chutes Extra heavy duty pavements Settling ponds &amp; sludge drying areas</i>	17	Standard Grey Coloured products on request	Horizontal and vertical interlock	240mm x 240mm x 100mm



**Please note the bedding and jointing sand should comply with SANS 1200MJ.**

Technicrete reserves the right to change or amend the contents of this document at anytime without any notice with this document intended for general information only. Any specific information required about product specifications, applications, technical information, sales conditions, warranties and guarantees as required for any design or installation should be obtained from Technicrete.

**Branches:**

**Carletonville:** 018 790-4380  
**Evander:** 017 689-2100  
**Stilfontein:** 018 484-6234

**White River:** 013 758-1203  
**Olifantsfontein:** 011 203-7700  
**Polokwane:** 015 298-8083  
**Welkom:** 057 391-4200  
**Witbank:** 013 696-1153

**BCT Rustenburg:** 014 538-0818  
**Port Elizabeth:** 041 372 2230