

TECHNICRETE

Kerbs

the ideal edge restraint

A range of precast concrete kerbs for use as an edge restraint in the construction of roads, footpaths, parking areas and various applications.

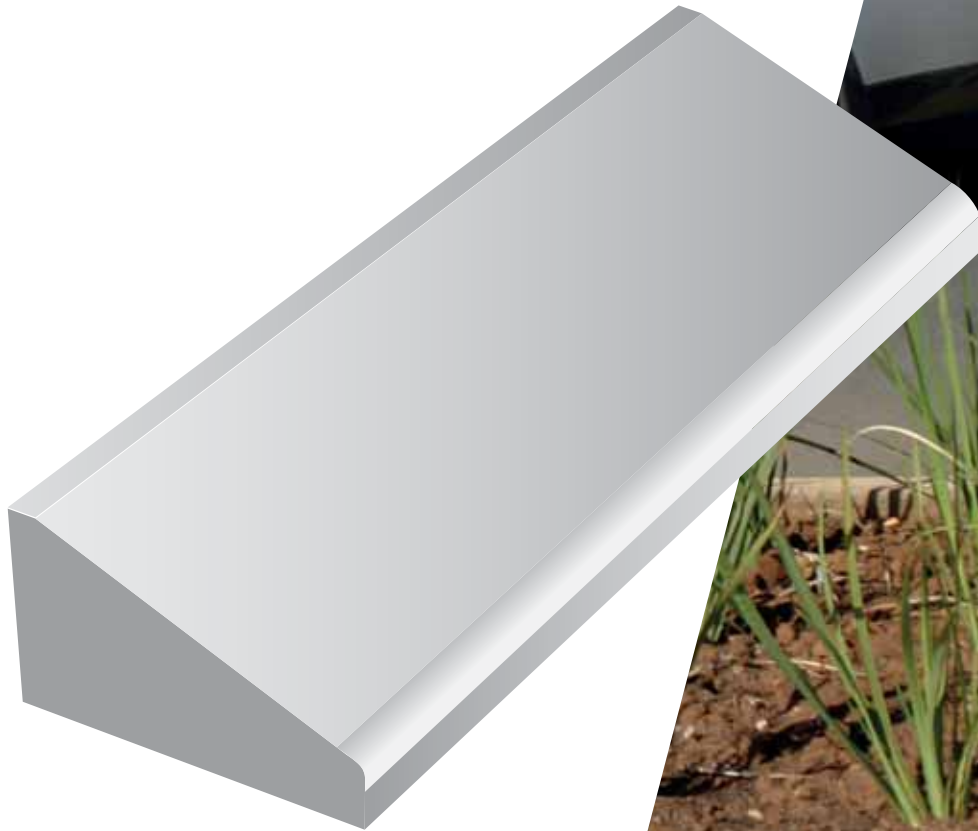

TECHNICRETE
quality support

CONCRETE ROOF TILES • EROSION PROTECTION BLOCKS • **KERBS** • MASONRY •
PAVING • PREBAGGED PRODUCTS • RETAINING WALLS • STOPE SUPPORT SYSTEMS

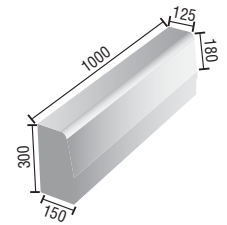
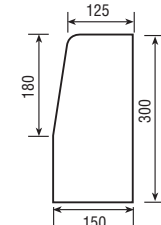
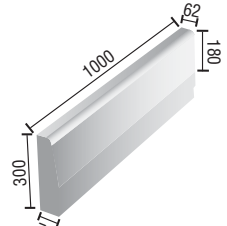
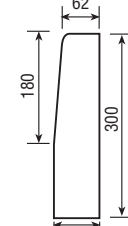
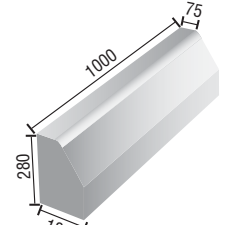
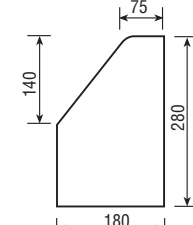
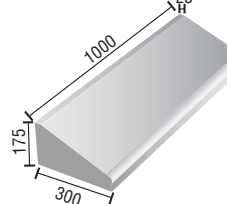
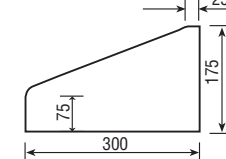
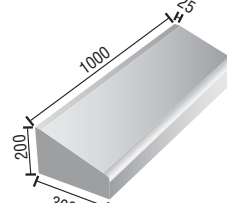
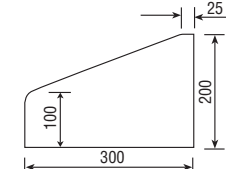
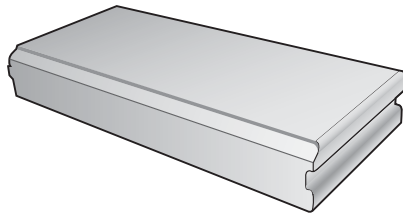
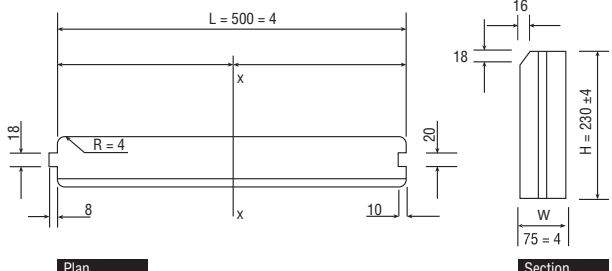

TECHNICRETE Concrete Kerbs the ideal edge restraint

<p>300 X 150 Barrier Kerb (fig 3)</p>		
<p>300 x 75 x 62 Barrier Kerb (fig 5)</p>		
<p>280 x 180 x 140 Semi Mountable (fig 7)</p>		
<p>300 x 175 x 75 Mountable (fig 8B)</p>		
<p>300 x 200 x 100 Mountable (fig 8C)</p>		
<p>230 x 75 Rectangular (Standard Industrial Kerb)</p>		

Technicrete reserves the right to change or amend the contents of this document at anytime without any notice with this document intended for general information only. Any specific information required about product specifications, applications, technical information, sales conditions, warranties and guarantees as required for any design or installation should be obtained from Technicrete.



TECHNICRETE
quality support

Technicrete House

Cnr. Main Reef Road & Houtkapper Street, Roodepoort, 1725
Tel: 011 674 6900 – Fax: 011 672 1425
Email: info@technicrete.co.za
www.technicrete.co.za
0861 266267



A Murray & Roberts company

Branches:

Carletonville: 018 790-4380
Evander: 017 689-2100
Stilfontein: 018 484-6234

White River: 013 750-0319
Olifantsfontein: 011 203-7700
Polokwane: 015 298-8083
Welkom: 057 391-4200
Witbank: 013 696-1153